

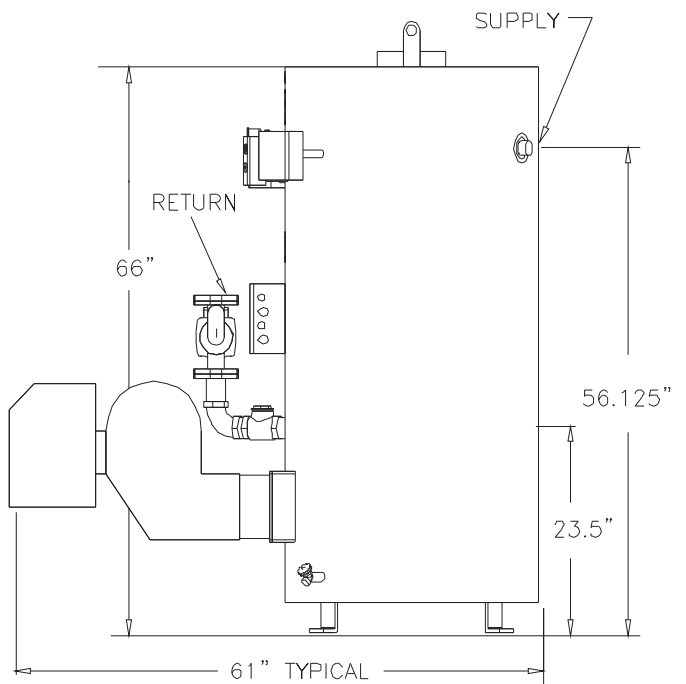

West Chicago, IL 60185  
Phone: 630-562-2700  
[www.triadboiler.com](http://www.triadboiler.com)

### TRIAD BOILER SYSTEMS, INC. SERIES 900 SPACE HEAT BOILER HYDRONIC PACKAGED FIRETUBE BOILERS

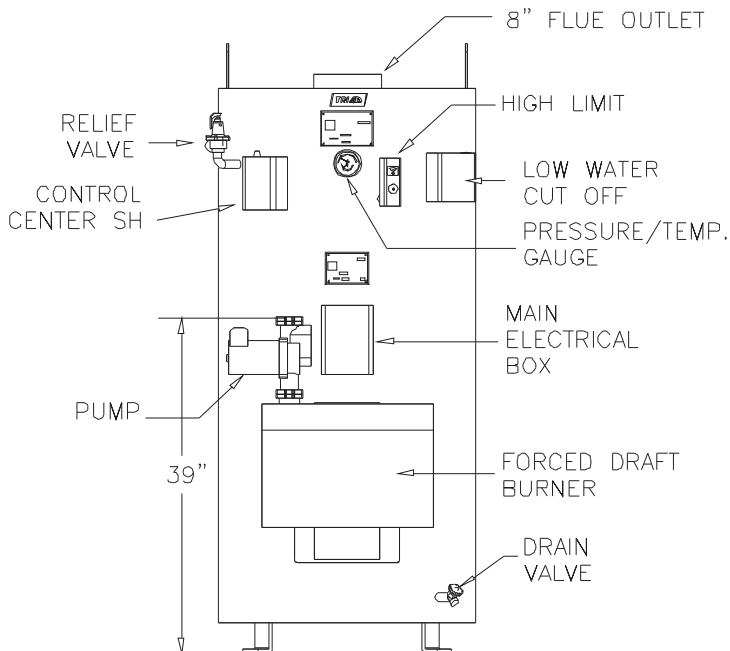
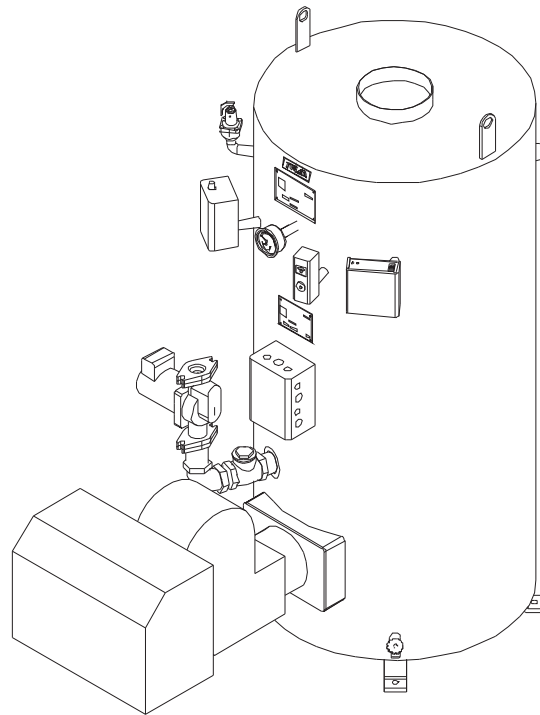
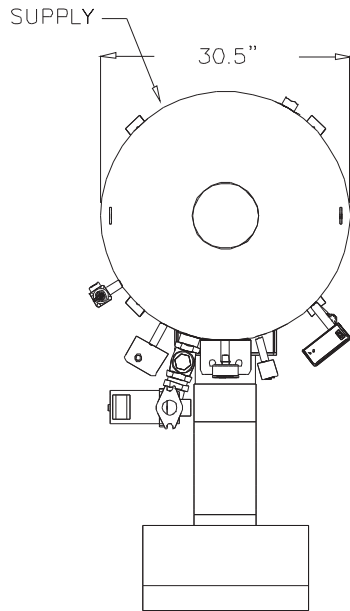

Note: Dimensions subject to change without notice.



**TRIAD BOILER SYSTEMS, INC.**  
**SERIES 900 SPACE HEAT BOILER (Model 900 SH)**

The Series 900 is a steel vertical firetube packaged boiler with a water-backed combustion chamber equipped with high-efficiency turbulators. Boilers come fully wired, and fit through a 32" doorway.

**STANDARD EQUIPMENT:**

- Forced Draft Burner (UL Listed)
- Circulating Pump
- Honeywell Control Center
- Low Water Cut-Off
- Combination Pressure/Temperature Gauge
- Operating Light
- Relief Valve
- Second Safety High Limit with Manual Reset
- Vessel Pressure Rating of 125 PSI

**OPTIONAL EQUIPMENT:**

- Gas Fired (NG or Propane), Oil Fired, or Dual Fuel Burners
- UL, IRI, FM and CSD-1 Compliance
- Low-High, Low-High-Low and Modulating Gas Trains
- Sealed Combustion Air Intake
- Barometric Dampers
- LWCO with Manual or Auto Reset, Test Light, and/or Test Button
- UL Listed Boiler/Burner Package.

**SPECIFICATIONS:**

<i>Input BTU/Hr</i>	<i>Output BTU/Hr</i>	<i>Efficiency</i>	<i>GPM @ °F Rise</i>
600,000	508,800	84.8%	50.8 @ 20°F
700,000	589,400	84.2%	58.9 @ 20°F
800,000	664,800	83.1%	66.7 @ 20°F
900,000	746,100	82.9%	59.6 @ 25°F
1,000,000	822,000	82.2%	66.7 @ 25°F

Note: Typical for Natural Gas. - Oil or LP burner data may vary.

**APPLICATIONS:**

Space Heating and Process Water – typically 130°F - 210°F

**CLEARANCES & CONNECTIONS:**

Clearance needed between boilers 6" (36" center to center) and 8" from front of burner for service.  
 Supply & return diameters – 2.00"

**CONTROL:**

The Series 900 can operate on its own controls, but a TRIAD microprocessor control panel is recommended for sequencing more than two boilers to minimize run-time and fuel usage.

**FLUE:** Category I or III depending on the installation and firing rate.

**POWER:** 120V, 60Hz, Single Phase, fused for 30 amps. Min / Max gas pressure, typically 5.6" / 14" WC

**WEIGHT/VOLUME:**

- Shipping Weight – 1,300 lbs.
- Operating Weight - 1,922 lbs.
- Water Volume – 75 Gallons

Factory built copper or steel mains available upon request.

ALL BURNER EQUIPMENT UL APPROVED

**TRIAD BOILER REPRESENTATIVE:**

**TRIAD Boiler Systems, Inc.**

West Chicago, IL 60185  
 Phone: 630-562-2700  
 Fax: 630-562-2800  
 Web: www.com.com