

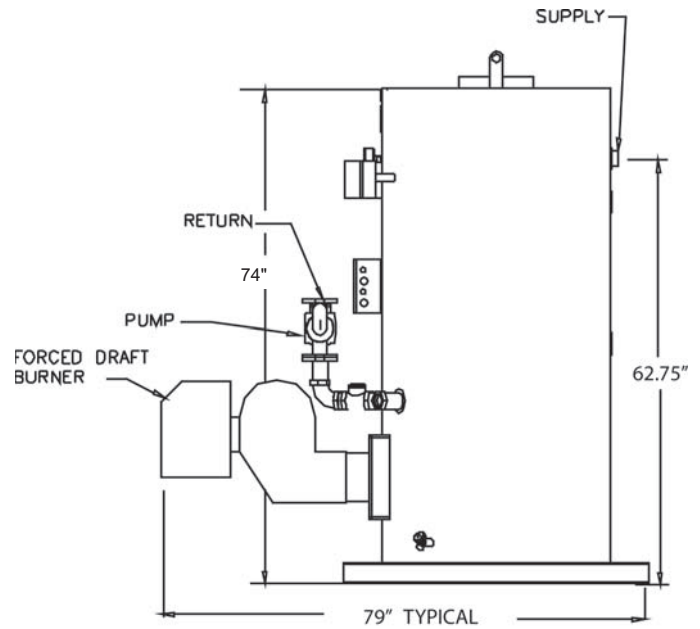

West Chicago, IL 60185  
Phone: 630-562-2700  
[www.triadboiler.com](http://www.triadboiler.com)

## TRIAD BOILER SYSTEMS, INC. SERIES 2000 SPACE HEAT BOILER

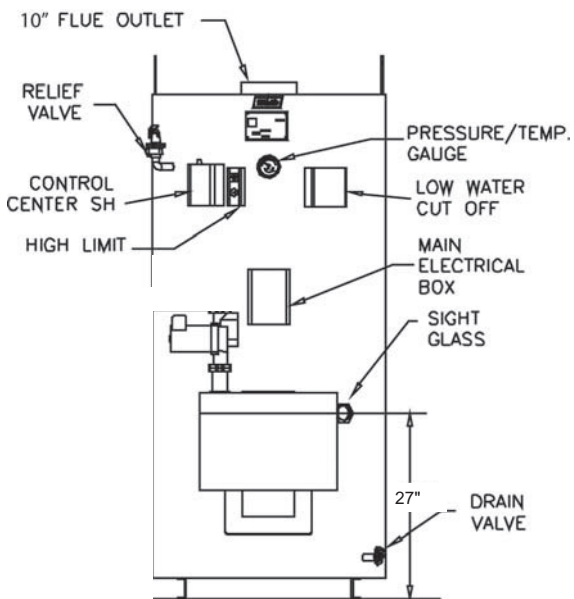
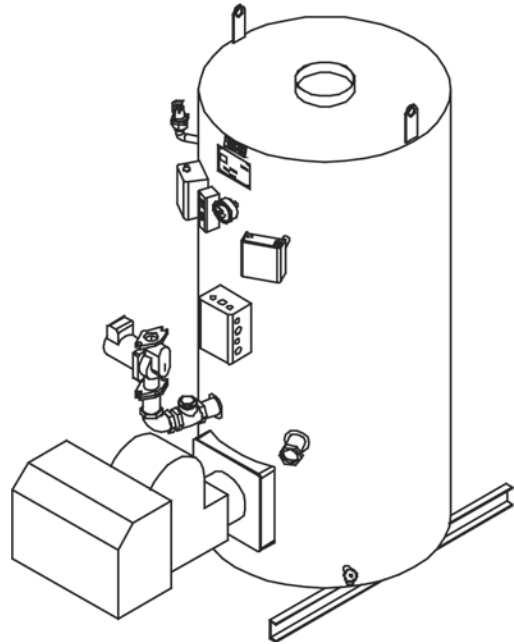
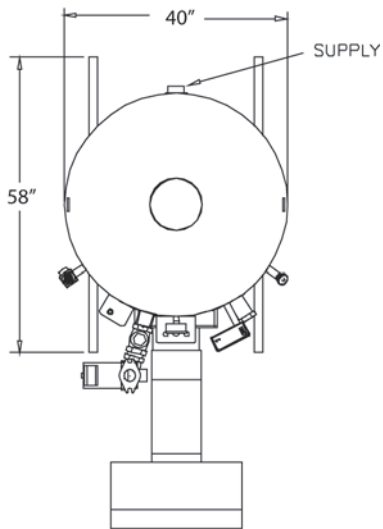

Note: Dimensions subject to change without notice.



**TRIAD BOILER SYSTEMS, INC.**  
**SERIES 2000 SPACE HEAT BOILER (Model SH)**

The Series 2000 is a steel vertical firetube packaged boiler with a water-backed combustion chamber equipped with high-efficiency turbulators. Boilers come fully wired.

**STANDARD EQUIPMENT:**

- Low/High/Off Riello (UL Listed)
- Honeywell Control Center
- Low Water Cut-Off
- Combination Pressure/Temperature Gauge
- Operating Light
- Relief Valve
- Second Safety High Limit with Manual Reset
- Vessel Pressure Rating of 100 PSI
- B&G Series 60 Circ Pump (Shipped Loose)

**OPTIONAL EQUIPMENT:**

- Gas Fired (NG or Propane), Oil Fired, or Dual Fuel Burners
- UL, IRI, FM and CSD-1 Compliance
- Low/High/Low and Modulating Gas Trains
- Sealed Combustion Air Intake
- Barometric Dampers

**SPECIFICATIONS:**

<i>Input BTU/Hr</i>	<i>Output BTU/Hr</i>	<i>Efficiency</i>
1,800,000	1,494,000	83.0%
1,900,000	1,577,000	83.0%
2,000,000	1,660,000	83.0%
2,100,000	1,172,200	82.0%
2,200,000	1,804,000	82.0%
2,300,000	1,886,000	82.0%

Note: Typical for Natural Gas. - Oil or LP burner data may vary.

**APPLICATIONS:**

Space Heating and Process Water – typically 140°F - 210°F

**CLEARANCES & CONNECTIONS:**

Clearance recommended between boilers - 6"; From front of burner for service – 10".  
Supply & Return Openings – 3.00"

**CONTROL:**

The Series 2000 can operate on its own controls, but a TRIAD microprocessor control panel is recommended for sequencing more than two boilers to minimize run-time and fuel usage.

**Flue:** Category I when applied appropriately.

**POWER:** 120V, 60Hz, Single Phase, fused for 30 amps. Min / Max gas pressure, typically 8.0" / 14" WC

**WEIGHT/VOLUME:**

Shipping Weight – 2000 lbs.  
Water Volume – 149 gallons

Factory built copper or steel mains available upon request.  
ALL BURNER EQUIPMENT UL APPROVED

**TRIAD BOILER REPRESENTATIVE:**

**TRIAD Boiler Systems, Inc.**

West Chicago, IL 60185  
Phone: 630-562-2700  
Fax: 630-562-2800  
Web: www.com.com