



B531 Series Commercial Regulator



Advanced Metering
and Regulation
Technology at Work



Features

- Interchangeable brass orifice
- Combined 54 in² of diaphragm area
- Twin spring-loaded internal relief valve assemblies
- Field interchangeable adjustment springs
- No special adjustment tools required
- Controlled size breather orifice eliminates pulsation and provides normal actuation at low flows
- Wide range of valve body sizes
- Six different assembly position options

Benefits

- Eliminates parallel regulator piping installations
- Light weight
- Fast response protects equipment from shock damage
- Field inspection of the Internal Monitor (IM) and Internal Relief valves without customer shut-off or by-pass
- Unmatched overpressure protection with Internal Monitor plus Internal Relief (IMR) option

Applications

Appropriate for Utility light to medium commercial service applications where a high degree of Safety or Overpressure Protection are required such as schools, hospitals, etc. The B531 is an excellent replacement for parallel regulator piping systems.

Model Descriptions Included in this Bulletin

B531N – The B531N is a spring loaded self-operated regulator with no internal relief. This regulator can be used on low or intermediate inlet pressures where an internal relief, or other type of over-pressure protection device is not required.

B531R – The B531R is the internal relief version of the B531R Series. This model features twin 1" internal relief valves. Due to its excellent relief characteristics, the B531R can be used on any inlet pressure system up to the regulator's maximum operating pressure rating.

B531IMN (See page 12 schematic) – The B531IMN is equipped with an Internal Monitor (IM) orifice that operates upon failure of the main valve. The "N" designation signifies No internal relief valve.

B531IMR (See Page 12 schematic) – The B531IMR is equipped with an Internal Monitor (IM) orifice as a primary form of overpressure protection that operates upon failure of the main valve. The B531IMR is also equipped with Secondary twin internal relief valves that

open in the event that both the main seat and the internal monitor cannot function.

B531IMRV (See page 12 schematic) – The B531IMRV is equipped with an Internal Monitor (IM) orifice as a primary form of overpressure protection that operates upon failure of the main valve. It is also equipped with the Vent-Hole "V" option which gives a warning indication that the regulator is on monitor control in the event of main valve failure. The vent-hole "V" option consists of a 0.049" hole in the sliding orifice that allows a small amount of gas to bleed into the downstream which causes the relief valves to "weep" gas. In the unlikely event the main valve and monitor valve fails to function, the B531IMRV is equipped with secondary or back-up twin internal relief valves.

Option Designations

- N** – No Internal Relief
- R** – Internal Relief
- IMR** – Internal Monitor with Internal Relief
- IMN** – Internal Monitor with no Internal Relief
- IMRV** – Internal Monitor with Internal Relief and Vent

Principle of Operation

The Series B531 is a Spring-Loaded regulator equipped with a valve body that is effectively two regulators in parallel. This design allows for nearly double the capacity that can be achieved with a single 6" diaphragm regulator. The B531 design is symmetric about that downstream piping so all parts are identical in both diaphragm cases.



Increasing Load - As downstream demand increases, the gray shaded pressure begins to fall. Both diaphragm cases of the B531 are adjusted to the same Set Point so they both respond as the

load changes. The loading springs push the diaphragms down which opens both valves and allows gas to flow into the downstream.

Decreasing Load - As downstream demand decreases, the gray shaded pressure begins to rise. The rise in pressure under the diaphragm overcomes the force of the adjustment spring. This repositions the diaphragms upward closing the main valves.

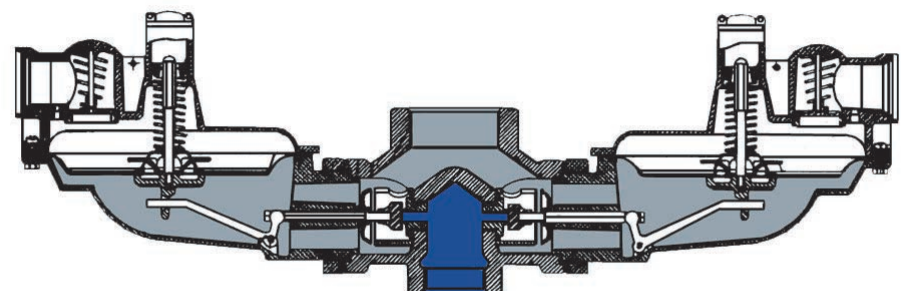
Operating Schematic



-  Inlet Pressure
-  Outlet Pressure

Specifications

Construction

Valve body	High tensile strength cast iron (ASTM A-126, Class A)
Orifices	Aluminum – R and N Models; Brass (ASTM B16, Alloy 360) - IMR, IMN, and IMRV models
Valve seats	Buna-N (standard) Silicone (for temperatures below -20° F)
Valve stems	Anodized Aluminum
Lever pins	Stainless steel (Type 303)
Levers	Zinc and dichromate plated steel (AISI C1010)
Upper diaphragm plates	Zinc and dichromate plated steel (14 gage steel)
Lower diaphragm plates	Die cast aluminum (ASTM B-85 Alloy SC84A)
Diaphragms	Buna-N and nylon reinforcing fabric
Vent valve seats	Neoprene
Vent screens	Stainless steel (16 mesh)
Adjustment ferrule	Cast aluminum (ASTM CS43A)
Seal caps	Die cast aluminum (ASTM CS43A)
Diaphragm cases	Die cast aluminum (ASTM B85 –Alloy SC84A)

Shipping Weight:

2 Regulators per box
Regulator weight: 22 lbs.
Gross weight per box: 45 lbs.

Correction factors for non-natural gas applications:

The B531 may be used to control materials other than natural gas. To determine the capacity of the B531 for gases other than natural gas, it will be necessary to multiply the values within the capacity tables by a correction factor. The table below lists the correction factors for some of the more common gases:

Gas Type	Specific Gravity	Correction Factor (CF)
Air	1.0	0.77
Butane	2.01	0.55
Carbon Dioxide (Dry)	1.52	0.63
Carbon Monoxide (Dry)	0.97	0.79
Natural Gas	0.60	1.00
Nitrogen	0.97	0.79
Propane	1.53	0.63
Propane-Air-Mix	1.20	0.71

To calculate the correction factor for gases not listed on the table above, it will be necessary to know the specific gravity of the gas and use it in the formula listed below:

$$\text{Correction Factor (CF)} = \sqrt{\frac{S.G.1}{S.G.2}}$$

Where:

- SG₁ = Specific Gravity of the gas in which the capacity is published.
- SG₂ = Specific Gravity of the gas to be controlled.

SPRING RANGES

Models N & R

SPRING COLOR	SPRING RANGE	Basic Setting
Brown	4.5 - 5.25" w.c.	5" w.c.
Dark Green	5.0 - 6.75" w.c.	6" w.c.
Light Green	5.5 - 7.5" w.c.	7" w.c.
Black	7.0 - 10.0" w.c.	9" w.c.
Blue	8.0 - 11.0" w.c.	11" w.c.
Silver	11.0 - 15.0" w.c.	14" w.c.
Red/Gray	0.75 - 1.1 psig	1.0 psig
Yellow	1.1 - 1.5 psig	1.25 psig
Red	1.3 - 2.0 psig	1.5 psig
White	1.75 - 2.5 psig	2.0 psig

Models IMN, IMR, IMRV

SPRING COLOR	SPRING RANGE	Basic Setting
Brown	4.5 - 5" w.c.	5" w.c.
Dark Green	5.5 - 6" w.c.	6" w.c.
Light Green	6 - 7" w.c.	7" w.c.
Black	7 - 9" w.c.	9" w.c.
Blue	8 - 10" w.c.	10" w.c.
Silver	9 - 13" w.c.	11" w.c.
White/Red	12" - 1 psig	1.0 psig
Yellow	1.1 - 1.5 psig	1.25 psig
Red	1.25 - 1.75 psig	1.5 psig
White	1.5 - 2.25 psig	2.0 psig

ORIFICE DATA - Wide Open Flow Coefficients and Maximum Pressures

Orifice Size	Wide-Open Orifice Coefficient (K-Factor)	Maximum Operating Inlet Pressure (psig)	Maximum Emergency Inlet Pressure (psig)	Maximum Emergency Outlet Pressure (psig)
1/8"	60	125	300	60
1/8" IM	70	125	300	
3/16"	140	125	300	
3/16" IM	135	125	300	
1/4"	155	125	300	
1/4" IM	130	60	300	
5/16"	187	75	150	
5/16" IM	180	60	150	
3/8"	580	60	150	
1/2"	1000	30	100	

For wide-open orifice flow calculations use the following equations:

$$\text{For } P_1/P_2 < 1.89 \text{ use: } Q = K \sqrt{P_1(P_1 - P_2)}$$

$$\text{For } P_1/P_2 > 1.89 \text{ use: } Q = 1/2 K P_1$$

Where: P₁ = absolute inlet pressure (psia)

P₂ = absolute outlet pressure (psia)

Q = flow rate (scfh)

K = orifice coefficient (scfh/psi)

VALVE BODY SIZES*

Inlet	Outlet
3/4"	3/4"
3/4"	1-1/4"
1"	1-1/2"
1"	2"
1-1/4"	1-1/4"
1-1/4"	1-1/2"
1-1/4"	2"

*All sizes available with 1/8" NPT inlet tap

MISCELLANEOUS SPECIFICATIONS

Available Vent Sizes: 3/4", & 1" NPT

Operating Temperature Range: -20 F to 150 F*

(Silicone valve seats available for applications below -20 F)

Loading Ring Position: Always 0 degrees (directly downstream)

Pressure Taps: Optional 1/8" NPT on inlet side

B531 DIMENSIONS

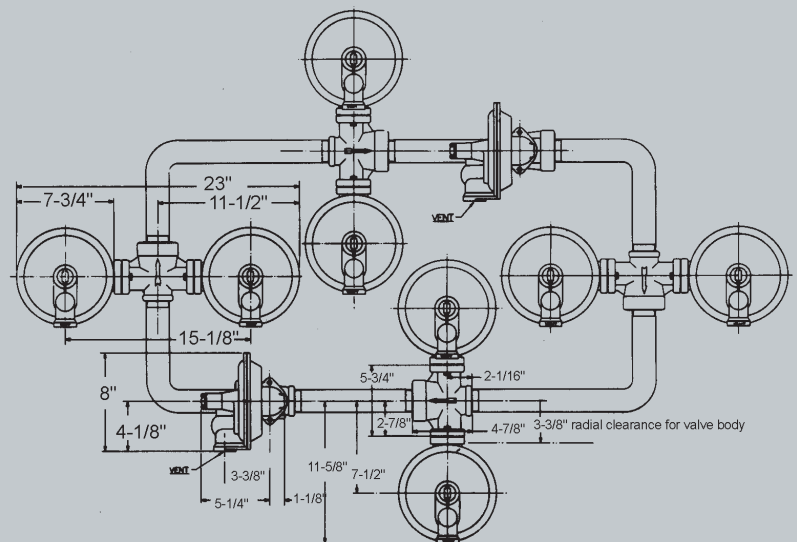

7" w.c. (17.5 mbar) Capacity Table (B531N & R Models) - Valve Body: 1-1/2" Outlet

1" w.c. Droop

Set Point: 7" w.c. (17.5 mbar) @ 200 scfh (5.68 m3/h)

Mounting Position 5

Valve Body: 1 1/4" x 1 1/2" NPT

Inlet Pressure		Capacities in scfh (m3/hr)					
		Orifice Size					
Psig	Bar	1/8"	3/16"	1/4"	5/16"	3/8"	1/2"
8	"w.c. 0.02						325 (9.1)
10	"w.c. 0.02				280 (7.8)	340 (9.5)	420 (11.8)
12	"w.c. 0.03			290 (8.1)	350 (9.8)	400 (11.2)	480 (13.4)
14	"w.c. 0.03		230 (6.4)	310 (8.7)	390 (10.9)	430 (12.0)	540 (15.1)
16	"w.c. 0.04		250 (7.0)	340 (9.5)	420 (11.8)	470 (13.2)	650 (18.2)
18	"w.c. 0.04		290 (8.1)	360 (10.1)	450 (12.6)	500 (14.0)	720 (20.2)
21	"w.c. 0.05		310 (8.7)	400 (11.2)	460 (12.9)	540 (15.1)	760 (21.3)
24	"w.c. 0.06		340 (9.5)	450 (12.6)	500 (14.0)	590 (16.5)	840 (23.5)
1	0.07	285 (8.0)	360 (10.1)	490 (13.7)	570 (16.0)	650 (18.2)	920 (25.8)
2	0.13	300 (8.4)	520 (14.6)	660 (18.5)	800 (22.4)	950 (26.6)	1250 (35.0)
3	0.20	365 (10.2)	610 (17.1)	800 (22.4)	1100 (30.8)	1150 (32.2)	1500 (42.0)
5	0.33	490 (13.7)	800 (22.4)	1050 (29.4)	1450 (40.6)	1700 (47.6)	2000 (56.0)
10	0.67	660 (18.5)	1220 (34.2)	1550 (43.4)	1850 (51.8)	2200 (61.6)	2650 (74.2)
20	1.33	1050 (29.4)	1850 (51.8)	2300 (64.4)	2650 (74.2)	2900 (81.2)	3150 (88.2)
30	2.00	1400 (39.2)	2400 (67.2)	2850 (79.8)	3000 (84.0)	2900 (81.2)	3400 (95.2)
40	2.67	1700 (47.6)	2900 (81.2)	3200 (89.6)	3000 (84.0)	2900 (81.2)	
50	3.33	2050 (57.4)	3250 (91.0)	3500 (98.0)	3000 (84.0)	3000 (84.0)	
60	4.00	2300 (64.4)	3300 (92.4)	3200 (89.6)	3100 (86.8)	3000 (84.0)	
75	5.00	2675 (74.9)	3478 (97.4)	2996 (83.9)	3317 (92.9)		
80	5.33	2940 (82.3)	3503 (98.1)	3277 (91.8)			
90	6.00	3070 (86.0)	3599 (100.8)	3422 (95.8)			
100	6.67	3050 (85.4)	3650 (102.2)	3800 (106.4)			
125	8.33	3200 (89.6)	3700 (103.6)	4000 (112.0)			

Increase in outlet pressure required for no flow (inches w.c.)	0.5	0.6	0.7	0.8	0.9	1.0
Change in inlet pressure required to change outlet pressure by 1" w.c. (psig)	100	90	60	45	30	20

———— Black Spring spring used above line; Lt. Green spring used below line

■ Inlet pressure is too low to achieve 7" w.c. set point

■ Inlet pressure exceeds orifice pressure rating

7" w.c. (17.5 mbar) Capacity Table (B531N & R Models) - Valve Body: 2" Outlet

1" w.c. Droop

Set Point: 7" w.c. (17.5 mbar) @ 200 scfh (5.68 m3/h)

Mounting Position 5

Valve Body: 1 1/4" x 2" NPT

Inlet Pressure		Capacities in scfh (m3/hr)					
		Orifice Size					
Psig	Bar	1/8"	3/16"	1/4"	5/16"	3/8"	1/2"
8" w.c.	0.02						325 (9.10)
10" w.c.	0.02				280 (7.84)	340 (9.52)	420 (11.76)
12" w.c.	0.03			290 (8.12)	350 (9.80)	400 (11.20)	480 (13.44)
14" w.c.	0.03		230 (6.44)	310 (8.68)	390 (10.92)	430 (12.04)	540 (15.12)
16" w.c.	0.04		250 (7.00)	340 (9.52)	420 (11.76)	470 (13.16)	650 (18.20)
18" w.c.	0.04		290 (8.12)	360 (10.08)	450 (12.60)	500 (14.00)	720 (20.16)
21" w.c.	0.05		310 (8.68)	400 (11.20)	460 (12.88)	540 (15.12)	760 (21.28)
24" w.c.	0.06		340 (9.52)	450 (12.60)	500 (14.00)	720 (20.16)	960 (26.88)
1	0.07	285 (7.98)	420 (11.76)	605 (16.94)	750 (21.00)	900 (25.20)	1400 (39.20)
2	0.13	300 (8.40)	575 (16.10)	830 (23.24)	1150 (32.20)	1450 (40.60)	2040 (57.12)
3	0.20	370 (10.36)	720 (20.16)	1070 (29.96)	1420 (39.76)	1700 (47.60)	2440 (68.32)
5	0.33	490 (13.72)	950 (26.60)	1460 (40.88)	1880 (52.64)	2280 (63.84)	3150 (88.20)
10	0.67	720 (20.16)	1480 (41.44)	2220 (62.16)	2920 (81.76)	3350 (93.80)	4000 (112.00)
20	1.33	1050 (29.40)	2300 (64.40)	2950 (82.60)	4200 (117.60)	4320 (120.96)	4850 (135.80)
30	2.00	1390 (38.92)	3120 (87.36)	4200 (117.60)	4780 (133.84)	4850 (135.80)	5300 (148.40)
40	2.67	1700 (47.60)	3750 (105.00)	5000 (140.00)	5200 (145.60)	5250 (147.00)	
50	3.33	2000 (56.00)	4600 (128.80)	5000 (140.00)	5300 (148.40)	5400 (151.20)	
60	4.00	2250 (63.00)	5000 (140.00)	5000 (140.00)	5850 (163.80)	5900 (165.20)	
70	4.67	2570 (71.96)	5000 (140.00)	5000 (140.00)	5900 (165.20)		
75	4.84	2975 (83.30)	5000 (140.00)	5000 (140.00)	5900 (165.20)		
90	6.00	3100 (86.80)	5000 (140.00)	5000 (140.00)			
100	6.67	3200 (89.60)	5000 (140.00)	5000 (140.00)			
125	8.33	3200 (89.60)	5000 (140.00)	5000 (140.00)			
Increase in outlet pressure required for no flow (inches w.c.)		0.5	0.6	0.7	0.8	0.9	1
Change in inlet pressure required to change outlet pressure by 1" w.c. (psig)		100	90	60	45	30	20

 Inlet pressure is too low to achieve 7" w.c. set point

 Inlet pressure exceeds orifice pressure rating

B531 Commercial Regulator

7" w.c. Performance and Relief Data

Typical Performance Curves

Type and Model.....B531 R
 Regulator:
 Inlet Size1-1/4" NPT
 Outlet Size.....2" NPT
 Orifice Size1/4"
 SpringBlack
 Set Point 7.0" wc with 40 psig inlet @
 200 scfh. All test results are reported
 at a base of 14.7 psia and 60 F, 0.6 S.G.
 Gas.



Relief Characteristic Curves R Model Only

Type and Model.....B531R
 Regulator:
 Inlet Size1-1/4" NPT
 Outlet Size.....2" NPT
 Vent Size1" NPT
 Set Point 7.0" w.c. at 200 scfh. All test
 results are reported at a base of 14.7
 psia and 60 F, 0.6 S.G. Gas.

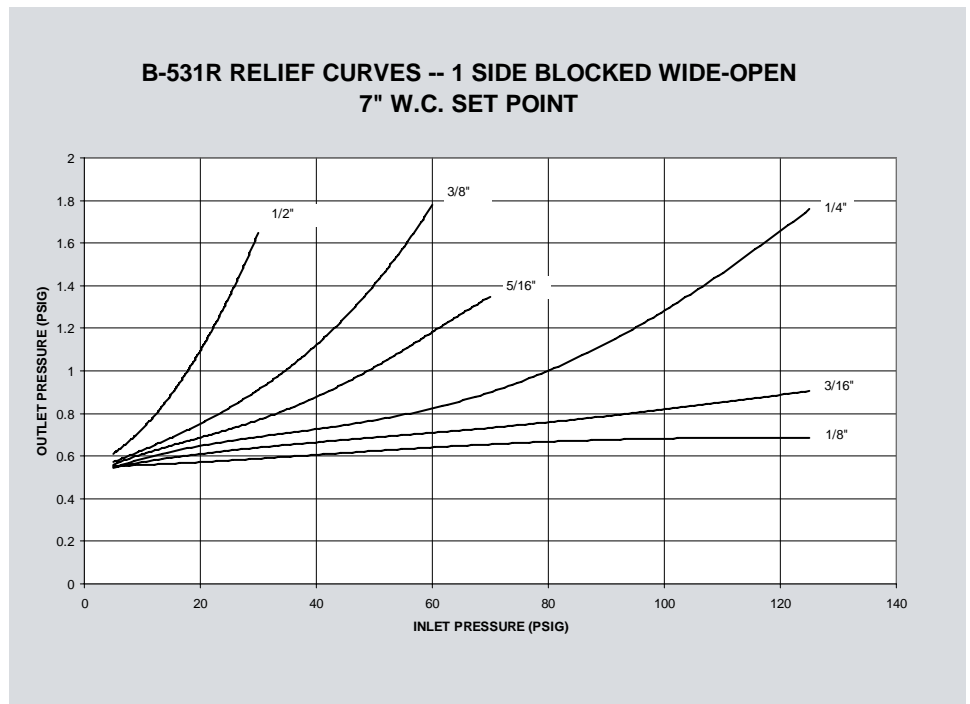

14" w.c. (35 mbar) Set Point Capacity Table (B531N & R Models) - Valve Body: 1-1/2" Outlet

2" w.c. Droop

Set Point: 14" w.c. (17.5 mbar) @ 200 scfh (5.68 m3/h)

Mounting Position 5

Valve Body: 1 1/4" x 1 1/2" NPT

Silver Spring

Inlet Pressure		Capacities in scfh (m3/hr)						
		Orifice Size						
Psig	Bar	1/8"	3/16"	1/4"	5/16"	3/8"	1/2"	
1	0.07		410 (11.48)	620 (17.36)	800 (22.40)	950 (26.60)	1400 (39.20)	
2	0.14	300 (8.40)	610 (17.08)	920 (25.76)	1150 (32.20)	1400 (39.20)	1800 (50.40)	
3	0.21	385 (10.78)	760 (21.28)	1160 (32.48)	1500 (42.00)	1620 (45.36)	2200 (61.60)	
5	0.34	510 (14.28)	1030 (28.84)	1480 (41.44)	1860 (52.08)	2150 (60.20)	2600 (72.80)	
10	0.69	715 (20.02)	1540 (43.12)	2240 (62.72)	2650 (74.20)	2950 (82.60)	3200 (89.60)	
20	1.38	1090 (30.52)	2300 (64.40)	3120 (87.36)	3500 (98.00)	3700 (103.60)	3900 (109.20)	
30	2.07	1380 (38.64)	2920 (81.76)	3600 (100.80)	3500 (98.00)	3700 (103.60)	4200 (117.60)	
40	2.76	1720 (48.16)	3400 (95.20)	3400 (95.20)	3700 (103.60)	4100 (114.80)		
50	3.45	2000 (56.00)	3700 (103.60)	3800 (106.40)	3900 (109.20)	4100 (114.80)		
60	4.14	2320 (64.96)	3950 (110.60)	3800 (106.40)	4000 (112.00)	4200 (117.60)		
75	5.17	2675 (74.90)	3745 (104.86)	3950 (110.60)	4387 (122.84)			
80	5.52	2995 (83.85)	3955 (110.74)	4060 (113.68)				
90	6.21	3200 (89.60)	4130 (115.64)	4250 (119.00)				
100	6.90	3300 (92.40)	4200 (117.60)	4300 (120.40)				
125	8.62	3500 (98.00)	4400 (123.20)	4400 (123.20)				

Lock-up Pressure (inches w.c.)	14.5	14.5	14.7	15.3	15.5	16
--------------------------------	------	------	------	------	------	----

14" w.c. (35 mbar) Set Point Capacity Table (B531N & R Models) - Valve Body: 2" Outlet

2" w.c. Droop

Set Point: 14" w.c. (17.5 mbar) @ 200 scfh (5.68 m3/h)

Mounting Position 5

Valve Body: 1 1/4" x 2" NPT

Silver Spring

Inlet Pressure		Capacities in scfh (m3/hr)						
		Orifice Size						
Psig	Bar	1/8"	3/16"	1/4"	5/16"	3/8"	1/2"	
1	0.07		410 (11.48)	620 (17.36)	800 (22.40)	950 (26.60)	1400 (39.20)	
2	0.14	300 (8.40)	610 (17.08)	920 (25.76)	1150 (32.20)	1400 (39.20)	1800 (50.40)	
3	0.21	385 (10.78)	760 (21.28)	1160 (32.48)	1500 (42.00)	1620 (45.36)	2240 (62.72)	
5	0.34	510 (14.28)	1030 (28.84)	1480 (41.44)	1860 (52.08)	2150 (60.20)	2920 (81.76)	
10	0.69	715 (20.02)	1540 (43.12)	2240 (62.72)	2650 (74.20)	3200 (89.60)	4050 (113.40)	
20	1.38	1090 (30.52)	2300 (64.40)	3200 (89.60)	4000 (112.00)	4550 (127.40)	5150 (144.20)	
30	2.07	1400 (39.20)	2950 (82.60)	4080 (114.24)	4800 (134.40)	5300 (148.40)	5200 (145.60)	
40	2.76	1720 (48.16)	3580 (100.24)	4700 (131.60)	5200 (145.60)	5900 (165.20)		
50	3.45	2000 (56.00)	4000 (112.00)	4860 (136.08)	5700 (159.60)	6000 (168.00)		
60	4.14	2320 (64.96)	4500 (126.00)	5150 (144.20)	6300 (176.40)	6150 (172.20)		
75	5.17	2775 (77.70)	4795 (134.26)	5665 (158.62)	6520 (182.56)			
80	5.52	2995 (83.85)	4810 (134.68)	5800 (162.40)				
90	6.21	3200 (89.60)	4900 (137.20)	5850 (163.80)				
100	6.90	3300 (92.40)	5020 (140.56)	5900 (165.20)				
125	8.62	3500 (98.00)	5100 (142.80)	5900 (165.20)				

Lock-up Pressure (inches w.c.)	14.5	14.5	14.7	15.3	15.5	16
--------------------------------	------	------	------	------	------	----

 Inlet pressure is too low to achieve 7" w.c. set point

 Inlet pressure exceeds orifice pressure rating

B531 Commercial Regulator

14" w.c. Performance and Relief Data

Typical Performance Curves

Type and Model.....B531 R
 Regulator:
 Inlet Size1-1/4" NPT
 Outlet Size.....2" NPT
 Orifice Size1/4"
 SpringSilver
 Set Point 14.0" wc with 40 psig inlet @ 200 scfh. All test results are reported at a base of 14.7 psia and 60 F, 0.6 S.G. Gas.

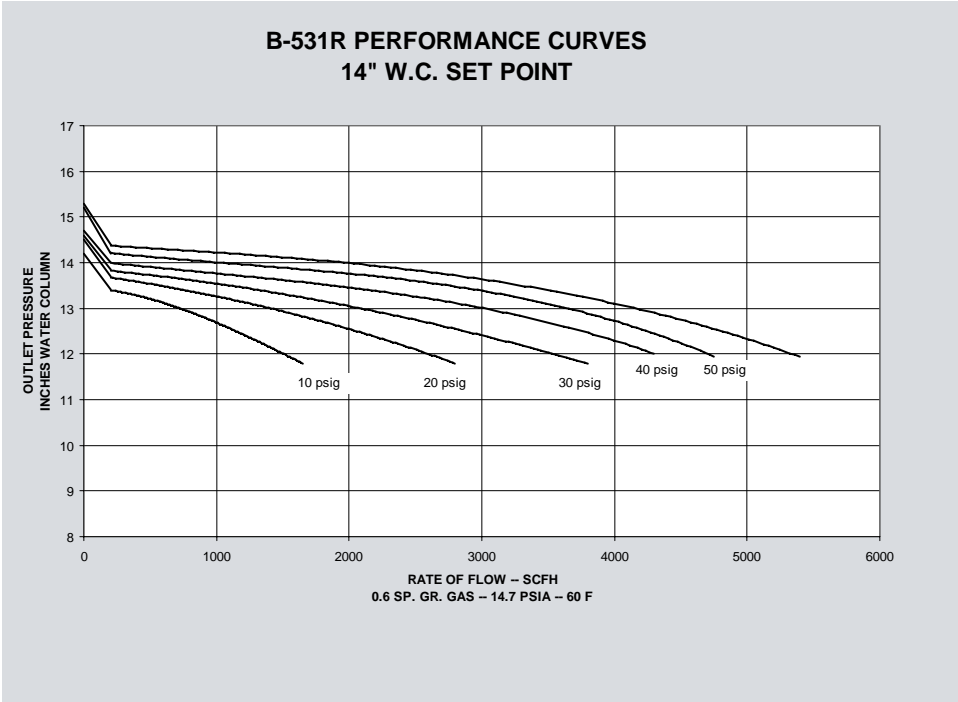

Relief Characteristic Curves R Model Only

Type and Model.....B531R
 Regulator:
 Inlet Size1-1/4" NPT
 Outlet Size.....2" NPT
 Vent Size1" NPT
 Set Point 14.0" w.c. at 200 scfh. All test results are reported at a base of 14.7 psia and 60 F, 0.6 S.G. Gas.

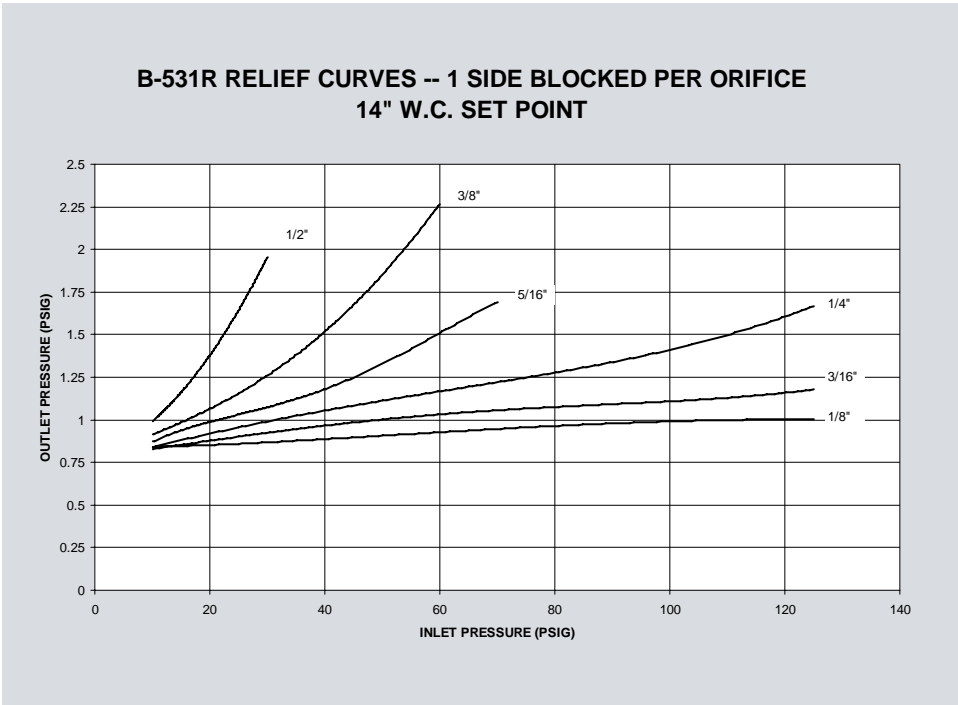

1 PSIG (69 mbar) Capacity Table (Models B531N & R) - All valve bodies

1% Absolute Droop (0.157 psi)

Set Point: 1 psig(mbar) @ 200 scfh (5.68 m3/h)

Mounting Position 5

Valve Body: 1 1/4" x 1 1/2" NPT

Inlet Pressure		Capacities in scfh (m3/hr)					
		Orifice Size					
Psig	Bar	1/8"	3/16"	1/4"	5/16"	3/8"	1/2"
2	0.14	255 (7.14)	440 (12.32)	630 (17.64)	750 (21.00)	930 (26.04)	1100 (30.80)
3	0.21	310 (8.68)	550 (15.40)	750 (21.00)	1050 (29.40)	1290 (36.12)	1400 (39.20)
5	0.34	415 (11.62)	735 (20.58)	780 (21.84)	1100 (30.80)	1300 (36.40)	1650 (46.20)
10	0.69	640 (17.92)	860 (24.08)	1120 (31.36)	1600 (44.80)	1800 (50.40)	2300 (64.40)
20	1.38	890 (24.92)	1300 (36.40)	1650 (46.20)	2400 (67.20)	3000 (84.00)	3600 (100.80)
30	2.07	1200 (33.60)	1800 (50.40)	2100 (58.80)	3100 (86.80)	3550 (99.40)	4100 (114.80)
40	2.76	1500 (42.00)	2100 (58.80)	2300 (64.40)	3700 (103.60)	3950 (110.60)	4200 (117.60)
50	3.45	1720 (48.16)	2800 (78.40)	2900 (81.20)	4000 (112.00)	4350 (121.80)	4800 (134.40)
60	4.14	2000 (56.00)	3100 (86.80)	3700 (103.60)	4300 (120.40)	4600 (128.80)	4900 (137.20)
70	4.83	2310 (64.68)	3585 (100.37)	4120 (115.35)	4601 (128.83)	4815 (134.82)	
80	5.52	2600 (72.80)	3730 (104.44)	4520 (126.56)	4972 (139.22)	5142 (143.96)	
90	6.21	2900 (81.20)	3890 (108.92)	4600 (128.80)	5310 (148.68)	5310 (148.68)	
100	6.90	3150 (88.20)	3990 (111.72)	4720 (132.16)	5700 (159.60)	5760 (161.28)	
125	8.62	3400 (95.20)	4170 (116.76)	4950 (138.60)	5900 (165.20)	5990 (167.72)	
Lock-up Pressure (psig)		1.02	1.03	1.05	1.07	1.1	1.1

1 PSIG (69 mbar) Capacity Table (Models B531N & R) - All valve bodies

2% Absolute Droop (0.314 psi)

Set Point: 1 psig (mbar) @ 200 scfh (5.68 m3/h)

Mounting Position 5

Valve Body: 1 1/4" x 1 1/2" NPT

Inlet Pressure		Capacities in scfh (m3/hr)					
		Orifice Size					
Psig	Bar	1/8"	3/16"	1/4"	5/16"	3/8"	1/2"
2	0.14	280 (7.8)	590 (16.5)	800 (22.4)	1000 (28.0)	1500 (42.0)	1900 (53.2)
3	0.21	375 (10.5)	790 (22.1)	1000 (28.0)	1500 (42.0)	1800 (50.4)	2300 (64.4)
5	0.34	530 (14.8)	1100 (30.8)	1250 (35.0)	1700 (47.6)	1950 (54.6)	2600 (72.8)
10	0.69	750 (21.0)	1300 (36.4)	1900 (53.2)	2400 (67.2)	2950 (82.6)	3700 (103.6)
20	1.38	1050 (29.4)	2050 (57.4)	2850 (79.8)	3900 (109.2)	4400 (123.2)	5300 (148.4)
30	2.07	1400 (39.2)	2750 (77.0)	3710 (103.9)	4650 (130.2)	5100 (142.8)	6100 (170.8)
40	2.76	1750 (49.0)	3350 (93.8)	4050 (113.4)	5400 (151.2)	5600 (156.8)	6800 (190.4)
50	3.45	1950 (54.6)	4050 (113.4)	4800 (134.4)	6000 (168.0)	6000 (168.0)	7000 (196.0)
60	4.14	2350 (65.8)	4500 (126.0)	5600 (156.8)	6100 (170.8)	6200 (173.6)	7100 (198.8)
70	4.83	2675 (74.9)	4922 (137.8)	6099 (170.8)	6520 (182.6)	6630 (185.6)	
80	5.52	2995 (83.8)	5311 (148.7)	6498 (181.9)	6890 (192.9)	7006 (196.2)	
90	6.21	3190 (89.3)	5780 (161.8)	6670 (186.8)	7200 (201.6)	7315 (204.8)	
100	6.90	3410 (95.5)	6120 (171.4)	6800 (190.4)	7410 (207.5)	7500 (210.0)	
125	8.62	3700 (103.6)	6400 (179.2)	6950 (194.6)	7500 (210.0)	7500 (210.0)	
Lock-up Pressure (psig)		1.02	1.03	1.05	1.07	1.1	1.1

Yellow Spring spring used above line; Red-Blue spring used below line

Inlet pressure exceeds orifice pressure rating

B531 Commercial Regulator

1 psig Performance and Relief Data

Typical Performance Curves

Type and Model.....B531 R

Regulator:

Inlet Size1-1/4" NPT

Outlet Size.....2" NPT

Orifice Size1/4"

SpringRed/Gray

Set Point 1 psig with 40 psig inlet @ 200 scfh. All test results are reported at a base of 14.7 psia and 60 F, 0.6 S.G. Gas.

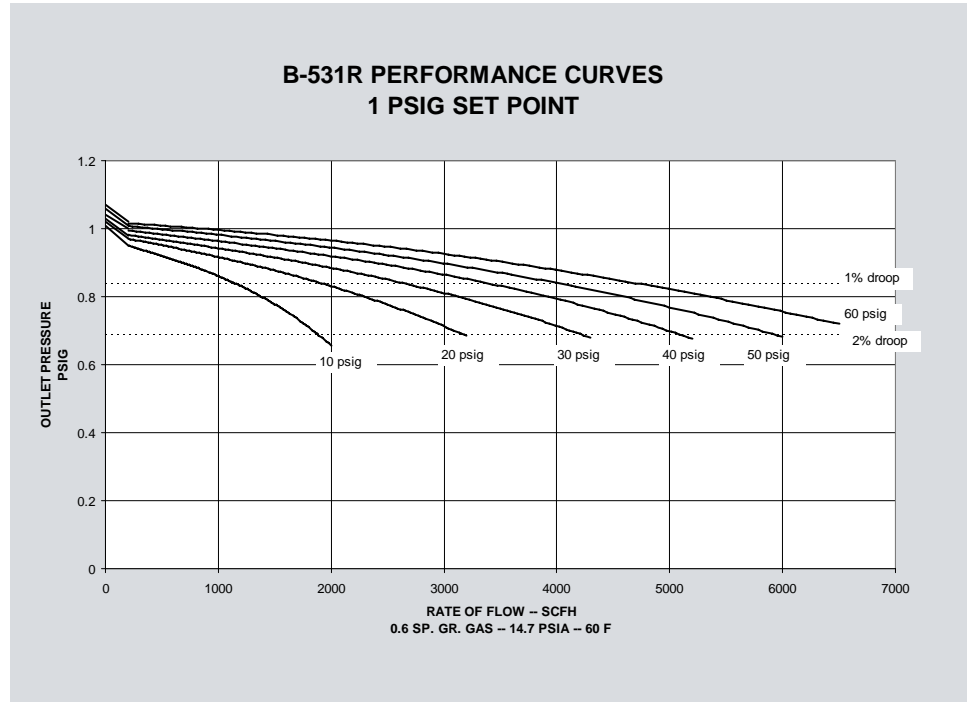

Relief Characteristic Curves R Model Only

Type and Model.....B531R

Regulator:

Inlet Size1-1/4" NPT

Outlet Size.....2" NPT

Vent Size1" NPT

Set Point 1 psig at 200 scfh. All test results are reported at a base of 14.7 psia and 60 F, 0.6 S.G. Gas.

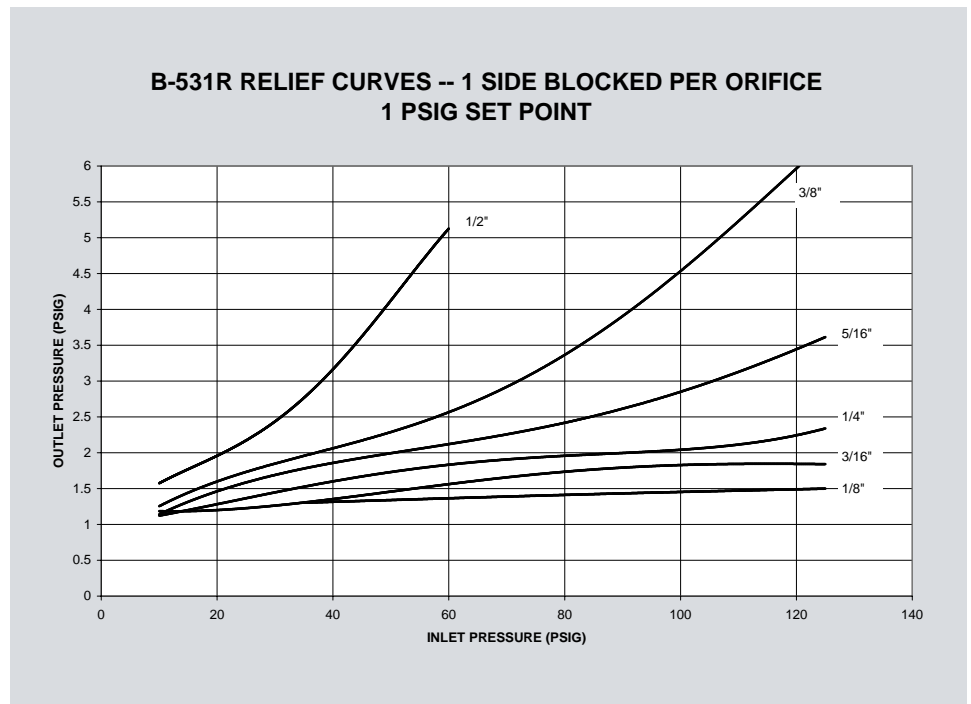

2 PSIG (69 mbar) Capacity Table (Models B531N & R) - All valve bodies

1% Absolute Droop (0.167 psi)

Set Point: 2 psig (mbar) @ 200 scfh (5.68 m3/h)

Mounting Position 5

Valve Body: All

White Spring

Inlet Pressure		Capacities in scfh (m3/hr)											
		Orifice Size											
Psig	Bar	1/8"		3/16"		1/4"		5/16"		3/8"		1/2"	
3	0.2	255	(7.14)	400	(11.20)	505	(14.14)	605	(16.94)	740	(20.72)	920	(25.76)
5	0.3	340	(9.52)	570	(15.96)	720	(20.16)	990	(27.72)	1100	(30.80)	1350	(37.80)
10	0.7	540	(15.12)	850	(23.80)	1150	(32.20)	1480	(41.44)	1780	(49.84)	2100	(58.80)
20	1.4	780	(21.84)	1230	(34.44)	1760	(49.28)	2200	(61.60)	2620	(73.36)	3100	(86.80)
30	2.1	1050	(29.40)	1800	(50.40)	2300	(64.40)	2700	(75.60)	3350	(93.80)	4020	(112.56)
40	2.8	1280	(35.84)	2100	(58.80)	2860	(80.08)	3300	(92.40)	3980	(111.44)	4400	(123.20)
50	3.4	1450	(40.60)	2550	(71.40)	3160	(88.48)	3800	(106.40)	4380	(122.64)	4750	(133.00)
60	4.1	1740	(48.72)	2620	(73.36)	3600	(100.80)	4000	(112.00)	4880	(136.64)	5600	(156.80)
70	4.8	1712	(47.94)	2940	(82.32)	4250	(119.00)	4685	(131.18)	5300	(148.40)		
80	5.5	1920	(53.76)	3220	(90.16)	4640	(129.92)	4910	(137.48)	5760	(161.28)		
90	6.2	2120	(59.36)	3360	(94.08)	4820	(134.96)	5100	(142.80)	6200	(173.60)		
100	6.9	2400	(67.20)	3480	(97.44)	4910	(137.48)	5220	(146.16)	6660	(186.48)		
125	8.6	2590	(72.52)	3610	(101.08)	5150	(144.20)	5430	(152.04)	6820	(190.96)		

Lock-up Pressure (psig)	2.05	2.05	2.1	2.1	2.2	2.3
-------------------------	------	------	-----	-----	-----	-----

2 PSIG (69 mbar) Capacity Table (Models B531N & R) - All valve bodies

2% Absolute Droop (0.33 psi)

Set Point: 2 psig (mbar) @ 200 scfh (5.68 m3/h)

Mounting Position: 5

Valve Body: All

White Spring

Inlet Pressure		Capacities in scfh (m3/hr)											
		Orifice Size											
Psig	Bar	1/8"		3/16"		1/4"		5/16"		3/8"		1/2"	
3	0.2	285	(7.98)	545	(15.26)	785	(21.98)	1050	(29.40)	1180	(33.04)	1600	(44.80)
5	0.3	440	(12.32)	810	(22.68)	1180	(33.04)	1540	(43.12)	1780	(49.84)	2340	(65.52)
10	0.7	685	(19.18)	1330	(37.24)	1870	(52.36)	2380	(66.64)	2820	(78.96)	3780	(105.84)
20	1.4	1090	(30.52)	2060	(57.68)	2980	(83.44)	3700	(103.60)	4250	(119.00)	5350	(149.80)
30	2.1	1400	(39.20)	2820	(78.96)	3800	(106.40)	4650	(130.20)	5450	(152.60)	6500	(182.00)
40	2.8	1700	(47.60)	3420	(95.76)	4500	(126.00)	5500	(154.00)	6600	(184.80)	7500	(210.00)
50	3.4	2020	(56.56)	3920	(109.76)	4950	(138.60)	6400	(179.20)	7100	(198.80)	7500	(210.00)
60	4.1	2200	(61.60)	4380	(122.64)	5500	(154.00)	7000	(196.00)	7500	(210.00)	7500	(210.00)
70	4.8	2745	(76.86)	5010	(140.28)	6070	(169.96)	7465	(209.02)	7500	(210.00)		
80	5.5	3130	(87.64)	5450	(152.60)	6920	(193.76)	7500	(210.00)	7500	(210.00)		
90	6.2	3245	(90.86)	5780	(161.84)	7420	(207.76)	7500	(210.00)	7500	(210.00)		
100	6.9	3400	(95.20)	6000	(168.00)	7500	(210.00)	7500	(210.00)	7500	(210.00)		
125	8.6	3510	(98.28)	6160	(172.48)	7500	(210.00)	7500	(210.00)	7500	(210.00)		

Lock-up Pressure (psig)	2.05	2.05	2.1	2.1	2.2	2.3
-------------------------	------	------	-----	-----	-----	-----

Inlet pressure exceeds orifice pressure rating

B531 Commercial Regulator

2 psig Performance and Relief Data

Typical Performance Curves

Type and Model.....B531 R
 Regulator:
 Inlet Size1-1/4" NPT
 Outlet Size.....2" NPT
 Orifice Size1/4"
 SpringWhite
 Set Point 2 psig with 40 psig inlet @ 200 scfh. All test results are reported at a base of 14.7 psia and 60 F, 0.6 S.G. Gas.

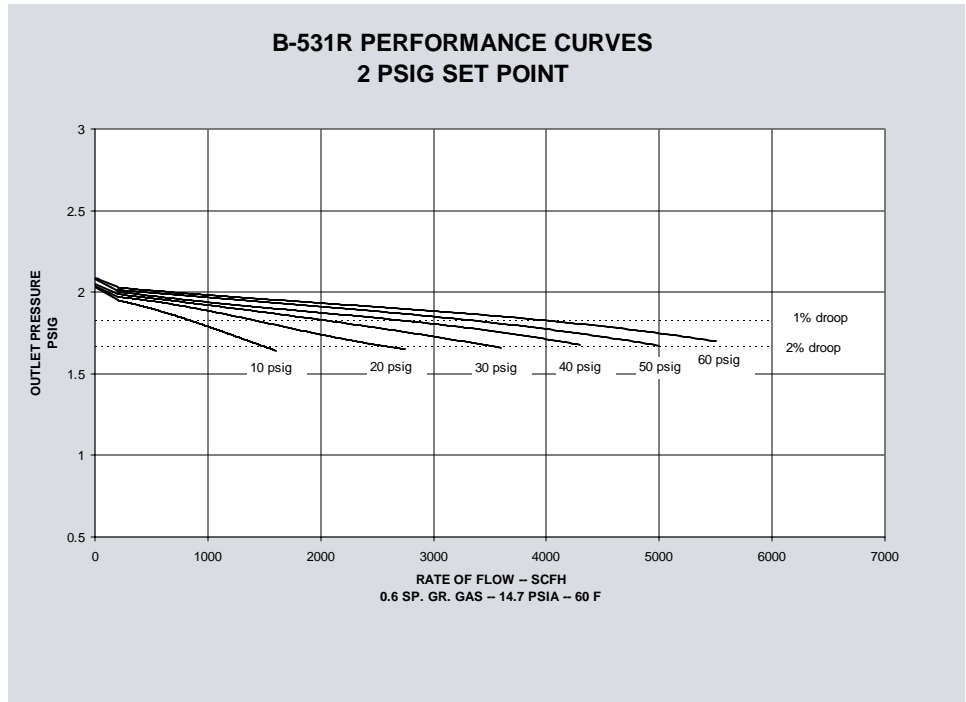

Relief Characteristic Curves R Model Only

Type and Model.....B531R
 Regulator:
 Inlet Size1-1/4" NPT
 Outlet Size.....2" NPT
 Vent Size1" NPT
 Set Point 2 psig at 200 scfh. All test results are reported at a base of 14.7 psia and 60 F, 0.6 S.G. Gas.

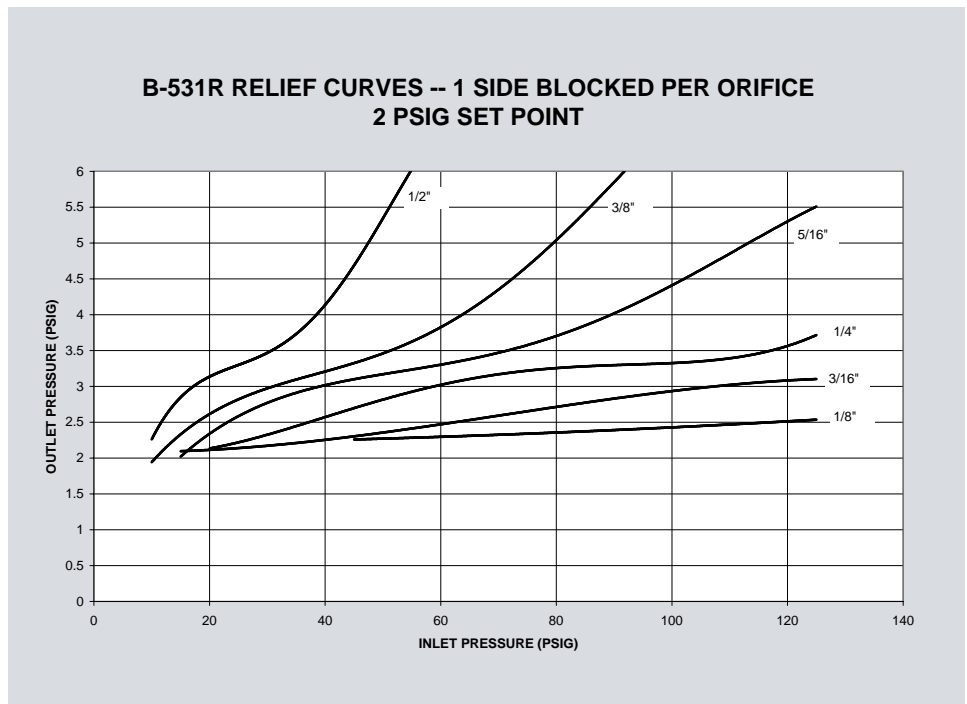

Internal Monitor (IM) Principal of Operation

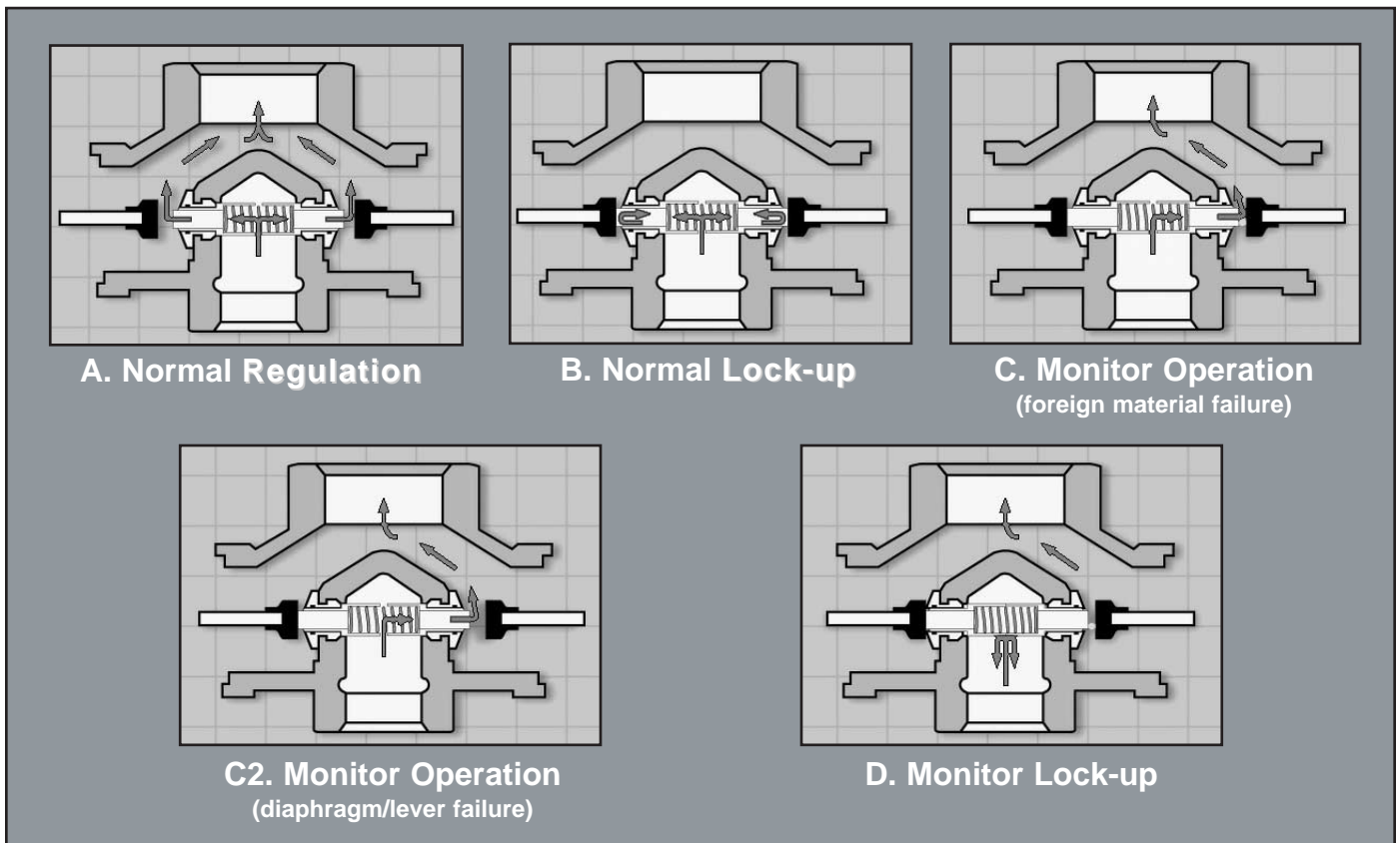

Internal Monitor Operation

A. Normal Operation -

The Internal Monitor Orifice operates like a standard one-piece orifice, performing normal regulation. The upstream Monitor remains wide-open.

B. Normal Lock-up - Regulator is free to lock-up in the usual manner. A nitrile O-ring forms a seal between the stationary and sliding orifices and prevents gas from leaking past the outer part of the orifice into the downstream or low pressure side of the valve body. The upstream Monitor remains wide open.

C. Monitor Operation - The monitor is comprised of one sliding orifice with a brass sharp edge and another sliding orifice with a vulcanized nitrile valve seat. If either of the main valves of the regulator fails to lock-up for any reason, the internal monitor orifice automatically goes into operation. Outlet pressure increases slightly, causing the valve seat to push against the inner or sliding part of the orifice, gradually compressing the monitor spring and closing the secondary or monitor orifice on the inlet side of the sliding orifices. At this point the B531IM operates as a monitor regulator.

C1. Foreign material failure - Assume a weld bead is caught between the orifice and the valve seat while in high flow operation. If the flow is reduced, the main valve tries to close, but cannot due to the foreign matter. The outlet pressure increases approximately 2" w.c. above the original set point (varies based on main valve set point) which starts to close the secondary monitor orifice. If the gas demand is decreased, the monitor orifice will be partially closed and becomes the new operating orifice. It will function as a monitor regulator keeping the outlet pressure approximately 3" w.c. above the set pressure for set pressure <1 psig or 0.5 psig for set pressure >1 psig.

C2. Diaphragm or Lever failure - While diaphragm or lever failure is an entirely unlikely situation, if this event happens the damaged side of the regulator will be unable to operate. The outlet pressure will then increase on the functional regulator and its sliding orifice moves to contact the monitor orifice and seat. However, since only one diaphragm is in operation, the outlet pressure will be about 4" w.c. higher on monitor operation than the normal set

point.

D. Monitor Lock-Up (No demand) - If the demand for gas downstream of the regulator is zero, the sliding orifices or orifice will close against the secondary rubber monitor seat and stop the gas flow completely.

E. Vent-Hole "V" option (not shown) - The sliding orifices of the "IMRV" model are equipped with 0.049" vent holes located near the "stepped" portion of the sliding orifice. During monitor operation, if the demand is very small or non-existent, the 0.049" vent holes will allow gas to bleed from the high pressure inlet side to the low pressure outlet side of the regulator. The pressure will build until the internal relief valve cracks (See Table 1 - pg. 13 for relief cracking pressure data). The relief valve will "weep" gas to the atmosphere giving a warning indication the regulator is not operating properly.

F. Regulator and Monitor failure (not shown) - In the unlikely event both the regulator and monitor fail, the B531IMR is equipped with twin internal relief valves that will be actuated by the "stop stem". Consult the factory at (800) 490-0657 for actual relief pressure data.

B531 Internal Monitor Lock-up and Relief Pressure Data

Set Point	Spring	IM Characteristic Data	
		IMR & IMN Lock-up ⁽¹⁾	IMRV Relief Point ⁽²⁾
7" w.c.	Black	12" w.c.	16" w.c.
14" w.c.	White/Red	24" w.c.	27" w.c.
1 psig	White/Red	1.4 psig	1.7 psig
2 psig	White	2.6 psig	2.8 psig

Note: Regulator failed with 1/4" plastic glued to seat

- (1) Outlet pressure required for Internal Monitor to close
 (2) Outlet pressure required to open the internal relief valve

7" w.c. (17.5 mbar) Capacity Table (B531IMN & IMR Models) - Valve Body: 1-1/2" Outlet

1" W.C. Droop

Set Point: 7" w.c. (17.5 mbar) @ 200 scfh (5.68 m3/h) Mounting Position 5
 Valve Body: 1 1/4" x 1-1/2" NPT Black Spring

Inlet Pressure		Capacities in scfh (m3/hr)			
		Orifice Size			
Psig	Bar	1/8"	3/16"	1/4"	5/16"
1	0.07		375 (10.50)	570 (15.96)	650 (18.20)
2	0.14	275 (7.70)	575 (16.10)	875 (24.50)	950 (26.60)
3	0.21	350 (9.80)	700 (19.60)	1100 (30.80)	1200 (33.60)
5	0.34	500 (14.00)	975 (27.30)	1350 (37.80)	1600 (44.80)
10	0.69	700 (19.60)	1400 (39.20)	2000 (56.00)	2300 (64.40)
15	1.03	950 (26.60)	1900 (53.20)	2500 (70.00)	2800 (78.40)
25	1.72	1300 (36.40)	2600 (72.80)	3000 (84.00)	3200 (89.60)
40	2.76	1750 (49.00)	3200 (89.60)	3200 (89.60)	3200 (89.60)
60	4.14	2400 (67.20)	3200 (89.60)	3200 (89.60)	3200 (89.60)
75	5.17	2900 (81.20)	3200 (89.60)		
90	6.21	3150 (88.20)	3200 (89.60)		
100	6.90	3200 (89.60)	3200 (89.60)		
125	8.62	3200 (89.60)	3200 (89.60)		

Lock-up Pressure (inches w.c.)	7.5	7.6	7.7	7.8

Inlet pressure is too low to achieve 7" w.c. set point

Inlet pressure exceeds orifice pressure rating

7" w.c. (17.5 mbar) Capacity Table (B531IMN & IMR Models) - Valve Body: 2" Outlet

1" W.C. Droop

Set Point: 7" w.c. (17.5 mbar) @ 200 scfh (5.68 m3/h)

Mounting Position 5

Valve Body: 1 1/4" x 2" NPT

Black Spring

Inlet Pressure		Capacities in scfh (m3/hr)			
		Orifice Size			
Psig	Bar	1/8"	3/16"	1/4"	5/16"
1	0.07		375 (10.50)	570 (15.96)	650 (18.20)
2	0.14	275 (7.70)	575 (16.10)	875 (24.50)	950 (26.60)
3	0.21	350 (9.80)	700 (19.60)	1100 (30.80)	1200 (33.60)
5	0.34	500 (14.00)	975 (27.30)	1350 (37.80)	1600 (44.80)
10	0.69	700 (19.60)	1400 (39.20)	2000 (56.00)	2500 (70.00)
20	1.38	1100 (30.80)	2200 (61.60)	3200 (89.60)	3800 (106.40)
30	2.07	1400 (39.20)	2900 (81.20)	4200 (117.60)	4400 (123.20)
40	2.76	1750 (49.00)	3600 (100.80)	4700 (131.60)	5000 (140.00)
50	3.45	2000 (56.00)	4100 (114.80)	5000 (140.00)	5000 (140.00)
60	4.14	2400 (67.20)	5000 (140.00)	5000 (140.00)	5000 (140.00)
70	4.83	2600 (72.80)	5000 (140.00)		
80	5.52	2900 (81.20)	5000 (140.00)		
90	6.21	3200 (89.60)	5000 (140.00)		
100	6.90	3500 (98.00)	5000 (140.00)		
125	8.62	4000 (112.00)	5000 (140.00)		

Lock-up Pressure (inches w.c.)	7.5	7.6	7.7	7.8
--------------------------------	-----	-----	-----	-----

14" w.c. (35 mbar) Set Point Capacity Table (B531IMN & IMR Models) - Valve Body: All

2" W.C. Droop

Set Point: 14" w.c. (35 mbar) @ 200 scfh (5.68 m3/h)

Mounting Position 5

Valve Body: 1 1/4" x 1-1/2" NPT

Black Spring

Inlet Pressure		Capacities in scfh (m3/hr)			
		Orifice Size			
Psig	Bar	1/8"	3/16"	1/4"	5/16"
1	0.07		290 (8.12)	350 (9.80)	410 (11.48)
2	0.14	265 (7.42)	370 (10.36)	460 (12.88)	595 (16.66)
3	0.21	315 (8.82)	455 (12.74)	550 (15.40)	720 (20.16)
5	0.34	415 (11.62)	545 (15.26)	715 (20.02)	920 (25.76)
10	0.69	575 (16.10)	775 (21.70)	1030 (28.84)	1220 (34.16)
15	1.03	680 (19.04)	1030 (28.84)	1280 (35.84)	1620 (45.36)
20	1.38	850 (23.80)	1230 (34.44)	1430 (40.04)	1980 (55.44)
30	2.07	1100 (30.80)	170 (4.76)	2020 (56.56)	2550 (71.40)
40	2.76	1420 (39.76)	2160 (60.48)	2420 (67.76)	3020 (84.56)
50	3.45	1750 (49.00)	2400 (67.20)	2740 (76.72)	3400 (95.20)
60	4.14	2100 (58.80)	2850 (79.80)	3000 (84.00)	3500 (98.00)
75	5.17	2500 (70.00)	3220 (90.16)		
85	5.86	2780 (77.84)	3520 (98.56)		
100	6.90	2910 (81.48)	4200 (117.60)		
125	8.62	3550 (99.40)	5120 (143.36)		

Lock-up Pressure (inches w.c.)	14.5	14.5	14.7	15.3
--------------------------------	------	------	------	------

 Inlet pressure is too low to achieve set point

 Inlet pressure exceeds orifice pressure rating

1 psig (70 mbar) Set Point Capacity Table (B531IMN & IMR Models) - Valve Body: All

1% Absolute Droop (0.157 psig)

Set Point: 1 psig (70 mbar) @ 200 scfh (5.68 m3/h)

Mounting Position 5

Valve Body: All

White-Red

Inlet Pressure		Capacities in scfh (m3/hr)			
		Orifice Size			
Psig	Bar	1/8"	3/16"	1/4"	5/16"
2	0.14		385 (10.78)	485 (13.58)	590 (16.52)
3	0.21	320 (8.96)	500 (14.00)	580 (16.24)	740 (20.72)
5	0.34	425 (11.90)	600 (16.80)	760 (21.28)	980 (27.44)
10	0.69	625 (17.50)	920 (25.76)	1060 (29.68)	1500 (42.00)
15	1.03	790 (22.12)	1230 (34.44)	1420 (39.76)	1920 (53.76)
20	1.38	990 (27.72)	1410 (39.48)	1720 (48.16)	2280 (63.84)
30	2.07	1280 (35.84)	1880 (52.64)	2320 (64.96)	3000 (84.00)
40	2.76	1660 (46.48)	2380 (66.64)	2850 (79.80)	3520 (98.56)
50	3.45	1880 (52.64)	2840 (79.52)	3220 (90.16)	3940 (110.32)
60	4.14	2260 (63.28)	3150 (88.20)	3520 (98.56)	4350 (121.80)
75	5.17	2700 (75.60)	3760 (105.28)		
85	5.86	2940 (82.32)	4000 (112.00)		
100	6.90	3320 (92.96)	4700 (131.60)		
125	8.62	4050 (113.40)	5720 (160.16)		

Lock-up Pressure (inches w.c.)	1.02	1.03	1.05	1.07
--------------------------------	------	------	------	------

1 psig (70 mbar) Set Point Capacity Table (B531IMN & IMR Models) - Valve Body: All

2% Absolute Droop (0.31 psig)

Set Point: 1 psig (70 mbar) @ 200 scfh (5.68 m3/h)

Mounting Position 5

Valve Body: All

White-Red

Inlet Pressure		Capacities in scfh (m3/hr)			
		Orifice Size			
Psig	Bar	1/8"	3/16"	1/4"	5/16"
2	0.14		520 (14.56)	675 (18.90)	825 (23.10)
3	0.21	380 (10.64)	640 (17.92)	860 (24.08)	1080 (30.24)
5	0.34	525 (14.70)	865 (24.22)	1180 (33.04)	1450 (40.60)
10	0.69	750 (21.00)	1350 (37.80)	1700 (47.60)	2240 (62.72)
15	1.03	930 (26.04)	1720 (48.16)	2200 (61.60)	2800 (78.40)
20	1.38	1100 (30.80)	2100 (58.80)	2700 (75.60)	3480 (97.44)
30	2.07	1450 (40.60)	2840 (79.52)	3620 (101.36)	4400 (123.20)
40	2.76	1800 (50.40)	3500 (98.00)	4300 (120.40)	5200 (145.60)
50	3.45	2080 (58.24)	4000 (112.00)	4800 (134.40)	5800 (162.40)
60	4.14	2320 (64.96)	4500 (126.00)	5350 (149.80)	6200 (173.60)
75	5.17	2890 (80.92)	5280 (147.84)		
85	5.86	3270 (91.56)	5630 (157.64)		
100	6.90	3670 (102.76)	6880 (192.64)		
125	8.62	4470 (125.16)	8380 (234.64)		

Lock-up Pressure (inches w.c.)	1.02	1.03	1.05	1.07
--------------------------------	------	------	------	------

Inlet pressure is too low to achieve set point

Inlet pressure exceeds orifice pressure rating

2 psig (0.14 bar) Set Point Capacity Table (B531IMN & IMR Models) - Valve Body: All

1% Absolute Droop (0.167 psig)

Set Point: 2 psig (0.14 bar) @ 200 scfh (5.68 m3/h)

Mounting Position 5

Valve Body: All

White

Inlet Pressure		Capacities in scfh (m3/hr)			
		Orifice Size			
Psig	Bar	1/8"	3/16"	1/4"	5/16"
3	0.21		375 (10.50)	450 (12.60)	570 (15.96)
5	0.34	380 (10.64)	530 (14.84)	630 (17.64)	830 (23.24)
10	0.69	570 (15.96)	775 (21.70)	1000 (28.00)	1300 (36.40)
15	1.03	735 (20.58)	940 (26.32)	1220 (34.16)	1640 (45.92)
20	1.38	900 (25.20)	1220 (34.16)	1550 (43.40)	1880 (52.64)
30	2.07	1200 (33.60)	1660 (46.48)	1950 (54.60)	2640 (73.92)
40	2.76	1460 (40.88)	2150 (60.20)	2560 (71.68)	3280 (91.84)
50	3.45	1700 (47.60)	2450 (68.60)	2780 (77.84)	3700 (103.60)
60	4.14	1980 (55.44)	2860 (80.08)	3300 (92.40)	3900 (109.20)
75	5.17	2450 (68.60)	3350 (93.80)		
85	5.86	2730 (76.44)	3730 (104.44)		
100	6.90	3040 (85.12)	4350 (121.80)		
125	8.62	3700 (103.60)	5300 (148.40)		

Lock-up Pressure (psig)	2.05	2.05	2.1	2.1
-------------------------	------	------	-----	-----

2 psig (0.14 bar) Set Point Capacity Table (B531IMN & IMR Models) - Valve Body: All

2% Absolute Droop (0.33 psig)

Set Point: 2 psig (0.14 bar) @ 200 scfh (5.68 m3/h)

Mounting Position 5

Valve Body: All

White

Inlet Pressure		Capacities in scfh (m3/hr)			
		Orifice Size			
Psig	Bar	1/8"	3/16"	1/4"	5/16"
3	0.21		510 (14.28)	670 (18.76)	770 (21.56)
5	0.34	450 (12.60)	725 (20.30)	960 (26.88)	1210 (33.88)
10	0.69	725 (20.30)	1180 (33.04)	1500 (42.00)	1920 (53.76)
15	1.03	920 (25.76)	1490 (41.72)	1960 (54.88)	2550 (71.40)
20	1.38	1090 (30.52)	1880 (52.64)	2400 (67.20)	3050 (85.40)
30	2.07	1450 (40.60)	2520 (70.56)	3300 (92.40)	4120 (115.36)
40	2.76	1740 (48.72)	3250 (91.00)	3950 (110.60)	5000 (140.00)
50	3.45	2080 (58.24)	3700 (103.60)	4560 (127.68)	5700 (159.60)
60	4.14	2380 (66.64)	4180 (117.04)	4900 (137.20)	6000 (168.00)
75	5.17	2920 (81.76)	4770 (133.56)		
85	5.86	3240 (90.72)	5220 (146.16)		
100	6.90	3670 (102.76)	6300 (176.40)		
125	8.62	4470 (125.16)	7680 (215.04)		

Lock-up Pressure (psig)	2.05	2.05	2.1	2.1
-------------------------	------	------	-----	-----

 Inlet pressure is too low to achieve set point

 Inlet pressure exceeds orifice pressure rating

INSTALLATION

- A. Make certain all shipping plugs are removed from the inlet, outlet and vent of any regulator before installation.
- B. When installing the regulator, the inside of the piping and the regulator inlet and outlet are to be clean, free of dirt, pipe dope and other debris to prevent entry into the regulator which could cause loss of pressure control.
- C. The pipe joint sealant should be applied on the male threads of the pipe. Do not use any pipe joint material on the female threads of the regulator or it could become lodged in the regulator causing possible loss of pressure control.
- D. Gas must flow through the valve body of the regulator in the same direction as the arrow cast on the body, or the outlet side of the regulator may be overpressured and damaged.
- E. When the regulator is installed OUTDOORS, the vent must always be positioned so that rain, snow, moisture or foreign particles cannot enter the vent opening. It is recommended that the vent be positioned to face downward so as to avoid entry of water or other matter which could interfere with the proper operation of the regulator. The vent should be located away from building eaves, window openings, building air intakes and above the expected snow level at the site. The vent opening should be inspected periodically to insure it does not become blocked by foreign material.
- F. When the regulator is installed INDOORS, the vents must be piped to the outside atmosphere while using the shortest length of pipe, the least number of elbows, and having as large a pipe diameter as the vent size or larger. USING VENT PIPE ANY SIZE SMALLER THAN THE VENT CONNECTION WILL LIMIT THE REGULATOR'S INTERNAL RELIEF VALVE CAPACITY. The outlet end of the pipe must be protected from moisture and the

entrance of foreign particles. The regulator should be specified by the user with the size vent and pipe threads desired to make the vent pipe connection.

START-UP PROCEDURE

- A. A pressure gauge should be mounted downstream of the regulator to monitor the downstream pressure.
- B. With the downstream valve closed, slowly open the inlet valve. The outlet pressure should rise to slightly greater than the set-point.
- C. Be sure there are no leaks and all connections are tight.
- D. The regulator has been preset at the factory to match specifications given when it was ordered. The outlet pressure may be adjusted by removing the seal caps on top of the spring housing and adjusting the ferrule or screw inside the spring housing using a large flat-head screwdriver or a spring adjustment tool available from Actaris.
- E. **Decreasing the outlet pressure**
- To adjust the regulator, open the downstream flow and observe the outlet pressure. If outlet pressure needs to be decreased: 1) Turn each adjustment screw counter-clockwise an equal number of turns to reduce the outlet pressure to a point just below the desired outlet pressure. Note: the outlet pressure will not drop until the second adjustment screw is turned. 2) Turn one screw clockwise until the desired outlet pressure is obtained. 3) Turn second screw clockwise until a slight increase in outlet pressure is observed. 4) Turn the second screw counter clockwise 1/4 turn to achieve the desired outlet pressure.
- F. After the desired outlet pressure is achieved, replace the seal cap, recheck for leaks. The regulator is ready for operation.
- G. **Increasing the outlet pressure** - If the outlet pressure needs to be

increased, adjust both sides to just below the desired set point. 1) Turn each adjustment screw counter-clockwise an equal number of turns to reduce the outlet pressure to a point just below the desired outlet pressure. Note: the outlet pressure will not drop until the second adjustment screw is turned. 2) Turn one screw clockwise until the desired outlet pressure is obtained. 3) Turn second screw clockwise until a slight increase in outlet pressure is observed. 4) Turn the second screw counter clockwise 1/4 turn to achieve the desired outlet pressure.

- H. After the desired outlet pressure is achieved, replace the seal cap, recheck for leaks. The regulator is ready for operation.

FIELD CHECK OF THE INTERNAL MONITOR

SAFETY WARNING:

FIELD CHECK OF THE INTERNAL MONITOR IS TO BE PERFORMED ON THE MODEL **B5311MR** ONLY! IT IS NOT TO BE PERFORMED ON MODELS **B5311MN** OR **B5311MRV**. DO NOT PERFORM INTERNAL MONITOR CHECK ON INDOOR INSTALLATIONS!

- A. **Checking Monitor Pressure Control** - A pressure gauge should be mounted downstream of the regulator to monitor the downstream pressure.
- B. While flowing gas through the regulator, remove both spring caps so both stop stems can be easily

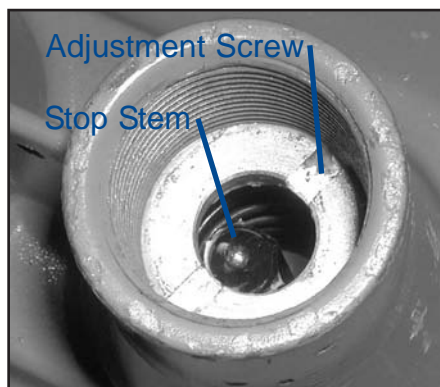

Fig. 1 - Stop Stem Location

seen and accessed (SEE Fig. 1).

C. While observing the downstream pressure gauge, begin pushing down on one of the stop stems. Doing so will force one side of the valve to open completely as shown in **Figure 3**. The downstream pressure will begin to rise until it reaches the monitor control pressure (SEE TABLE 1 - PAGE 13).

D. Release the stop stem and repeat the procedure on the other stop stem.



Fig. 2 - Pushing the Stop Stem

monitor lock-up pressure (SEE TABLE 1 - PAGE 13 for lock-up data).

G. Release the stop stem and repeat the procedure on the other stop stem.

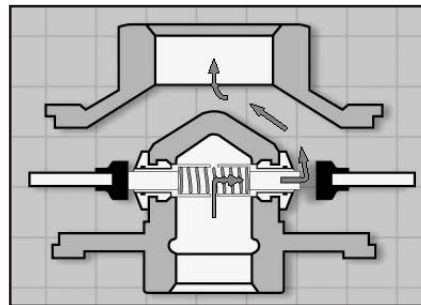

Fig. 3 - Monitor Operation with one side pushed open

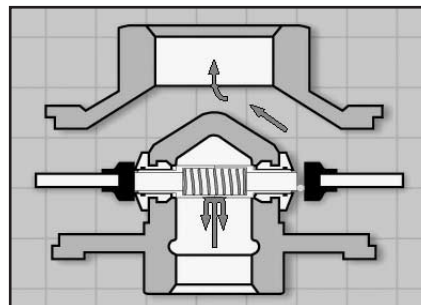

Fig. 4 - Monitor Lock-up

SAFETY WARNING!

DO NOT CONTINUE TO PUSH DOWNWARD ON THE STOP STEM AFTER THE MONITOR HAS TAKEN OVER PRESSURE CONTROL. DOING SO CAN RESULT IN THE RELEASE OF GAS THROUGH THE REGULATOR'S INTERNAL RELIEF VALVE.

E. **Checking Monitor Lock-up** - A pressure gauge should be mounted downstream of the regulator to monitor the downstream pressure.

F. With the downstream isolation valve closed and no gas flowing through the regulator, begin pushing down on one of the stop stems. Doing so will force one side of the valve to open completely as shown in **Figure 3**. The downstream pressure will begin to rise until it reaches the

SAFETY NOTES:

- A. The maximum inlet pressure for this regulator is dependent upon the size of the orifice and model designation. The non-relief models are limited to 60 psig maximum inlet pressure unless additional safety devices are used as outlined in DOT code, OPS, Part 192, section 192.197.
- B. When these models are used on liquid petroleum gases, they should be restricted to second-stage pressure reduction in the gaseous phase.

SAFETY WARNING!

THIS PRODUCT, AS OF THE DATE OF MANUFACTURE, IS DESIGNED AND TESTED TO CONFORM TO ALL GOVERNMENTAL OR INDUSTRY SAFETY STANDARDS THEN EXISTING AS MAY APPLY TO THE MANUFACTURER.

THE PURCHASER AND USER OF THIS PRODUCT ARE WARNED THAT COMPLIANCE WITH THE MANUFACTURER'S INSTRUCTIONS AND PROCEDURES IS REQUIRED IN ORDER TO AVOID THE HAZARDS OF LEAKING GAS RESULTING FROM IMPROPER INSTALLATION, START-UP OR USE OF THIS PRODUCT, AND FURTHER, THAT ALL AREA FIRE CONTROL, BUILDING CODES OR OTHER SAFETY REGULATIONS ESTABLISHED UNDER PUBLIC LAWS WHICH REGULATE OR CONCERN THE APPLICATION, INSTALLATION, OPERATION OR GENERAL USE OF THIS PRODUCT SHOULD BE COMPLIED WITH.

IN ORDER TO INSURE THE SAFE AND PROPER OPERATION OF THIS PRODUCT, THE MANUFACTURER RECOMMENDS THAT THIS PRODUCT BE INSTALLED BY A QUALIFIED INSTALLER.

Ordering Information

Specify:

1. Inlet and outlet connection size and body type
2. Model number
3. Outlet pressure desired
4. Inlet pressure range
5. Type of gas and maximum capacity in scfh required
6. Assembly position (see chart to right)
7. Vent Size
8. Special requirements such as:
 - badging or tagging
 - pressure tap on valve body
 - seal wire
 - silicone valve seats for temp. < -20 F

Reference Information

- Installation and Maintenance Instructions
- Parts List

Assembly Positions - All Models

Shown are 6 basic positions for assembling the model B-531 regulator. Specify the assembly position desired by letter when ordering.

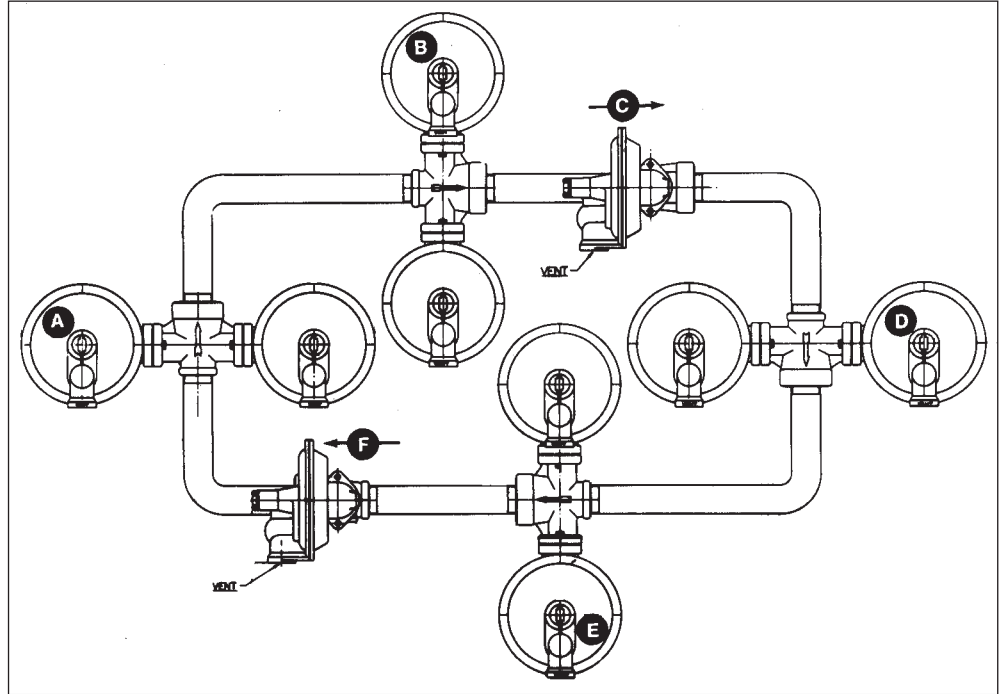

Warranty

Actaris Metering Systems, 970 Highway 127 North, Owenton, Kentucky 40359-9802, warrants this gas product against defects in materials and workmanship for the earlier of one (1) year from the date the product is shipped by Actaris or a period of one year from the date the product is installed at the original purchaser's site. During such one-year period, provided that the original purchaser continues to own the product, Actaris will, at its sole option, repair any defects, replace the product or repay the purchase price.

This warranty will be void if the purchaser fails to observe the procedures for installation, operation or service of the product as set forth in the Operating Manual and Specifications for the product or if the defect is caused by tampering, physical abuse or misuse of the product.

Actaris specifically disclaims all implied warranties including those of merchantability or of fitness for a particular purpose. Under no circumstances will Actaris be liable for incidental or consequential damages of any kind whatsoever.

The liability for any claim of any kind, including negligence and breach of warranty for the sale and use of any product covered by or furnished, shall in no case exceed the price allocable to the product or part thereof which gives rise to the claim.

In the event of a malfunction of the product, consult your Actaris Service Representative or Actaris Metering Systems, 970 Highway 127 North, Owenton, Kentucky 40359-9802.

Istec Corporation
Telephone: (973) 383-9888
Fax: (973) 383-9088

www.istec-corp.com

